

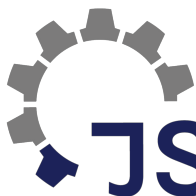

*CNC Vertical Boring & Turning Mills*

# ***VTB/VTC Series***

**VTB-100T/100/125/140/160/125E/140E/160E/200E/250E**  
**VTC-100/125/140/160/125E/140E/160E/200E/250E**



Generalimporteur  
Vertrieb & Service

**JS** WERKZEUG  
MASCHINEN

Vertrieb & Service

**STIENS**  
Werkzeugmaschinen



CNC Vertical Boring & Turning Mills

# VTB/VTC Series

100T/100/125/140/160/125E/140E/160E/200E/250E

**Heavy Duty, High Precision, Vertical Boring and Turning Mills  
Designed to Deliver Superior Performance**

■ **High Productivity**

- Maximum 1250 to 3000mm turning capacity
- Maximum 4 to 15 tons load capable table
- Elevating cross rail of 700 and 1000mm travel
- Full controlled C-axis and rotary spindle (only for VTC)
- Automatic tool changing system up to 12/24 (VTB/VTC) tools

■ **High Reliability**

- Heavy duty, wide guide ways of box type
- Massive one-piece cast iron bed, column, saddle, and cross-rail
- Induction-hardened and precise-ground guide ways
- Extra large 220, 240 and 280mm square spheroidal-graphite-iron ram
- The saddle enclosing the ram is one-piece casting to keep the high rigidity

■ **High Accuracy**

- Qualified precision bearings & ball screws
- Fluoroplastic-bonded & hand-scraped guide ways
- Full automatic lubrication to all critical areas



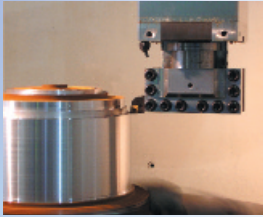

Turning

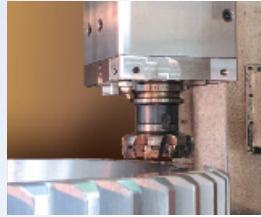

Face milling

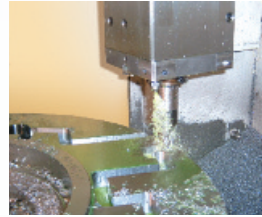

End milling

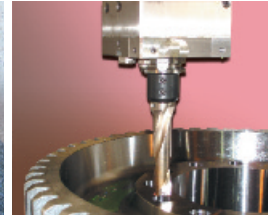

Drilling



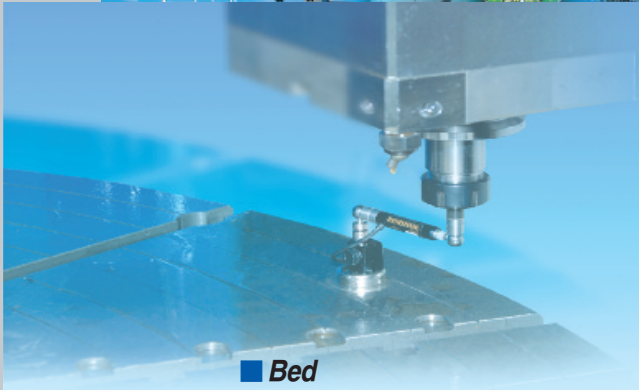

**Bed**

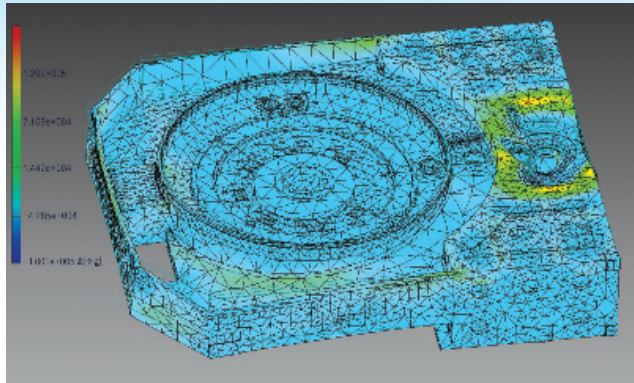

The stress analysis was applied to the bed structure design for maintaining the best condition to support the heavy load and cutting force and to minimize the distortion, deflection and dampen vibration.

**Table & Spindle Bearings**

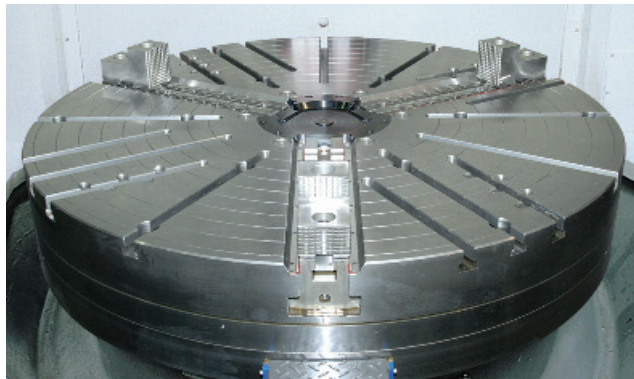

- Heavy duty table and large diameter high precision spindle bearings guarantee heavy loads and precise machining.
- Heavy duty 4-jaw independent chuck is standard (max. clamping force 4 metric tons). Hydraulic power chuck and automatic pallet changer system are available.
- The main spindle and drive gears are made of special alloy steel. They are induction hardened, fully stress relieved, and then precision ground for maximum performance.
- The power is transmitted to the table through the automatically shifted two speed gear box which generates enough speed and torque to satisfy wide spectrum of most demanding machining requirement.
- Helical gears are used for smooth and efficient power transmission characteristics.
- High-accurate table index by C-axis control: 0.001° on model VTC.
- Forced lubrication system provided.

**Machine Construction**

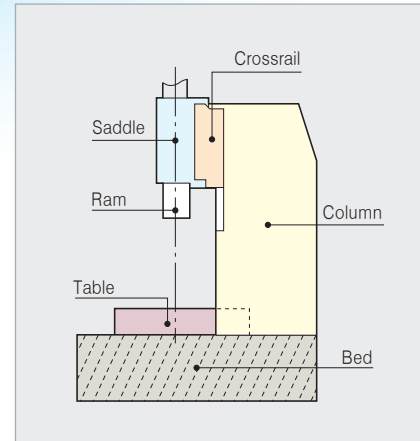

The column, cross rail, bed, saddle, and table are constructed of high quality Meehanite cast iron.

These main components are densely ribbed, thick walled, and fully stress relieved for long lasting accuracy.

**Motor & Table Gear**

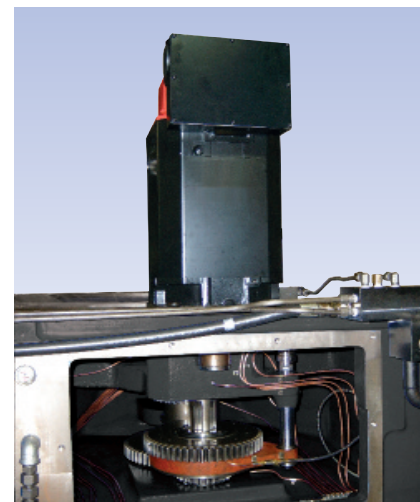

A direct connection of drive gear train to the motor minimize the loss of torque.

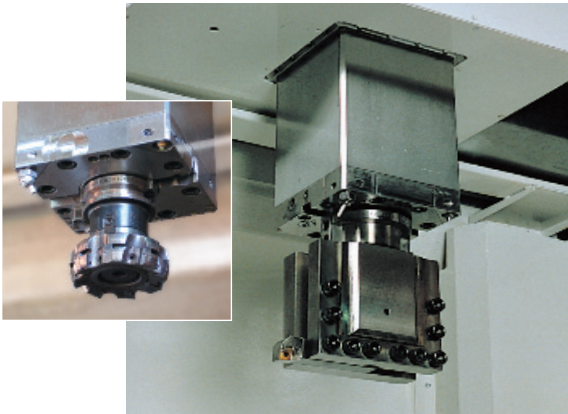

### ■ Saddle & Ram

- The saddle enclosing the ram is one-piece casting to keep the high rigidity.
- Huge 220, 240 and 280mm square spheroidal graphite iron ram, hardened and ground, is encased in the heavily ribbed saddle and is hydraulically counter balanced.
- Low friction fluoroelastic resin bonded to the ram sliding surfaces of the saddle minimizes friction.
- Model VTC has milling spindle with high-speed that involves drilling, milling, and tapping.
- Pull stud tool mounting and dismounting way of machining center type (P50T-I / DIN. 69872.50).
- Automatic metered lubrication system ensures lasting accuracy.
- Tool fall-safety device assures safe operation.

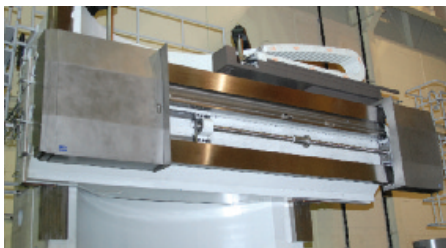

### ■ Elevating Cross Rail (VTB/VTC-E)

Vertical positioning of this massive cross rail is hydraulically powered. Positioning accuracy is assured by automatically actuated precision pins and 37.4 tons of hydraulic clamping force.

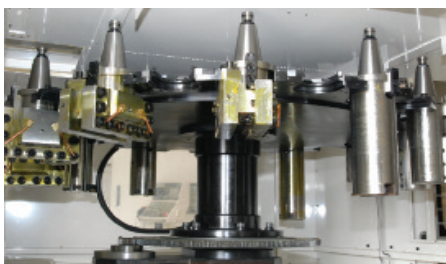

### ■ Automatic Tool Changer

The standard 12 tool capacity (24 tools for model VTC) automatic tool changer system and a wide variety of available tooling enable uninterrupted fully automatic machining possible. This rigidly constructed carousel type tool changer features high speed random indexing and is capable of safely handling tools of up to 70kg (150 pounds).

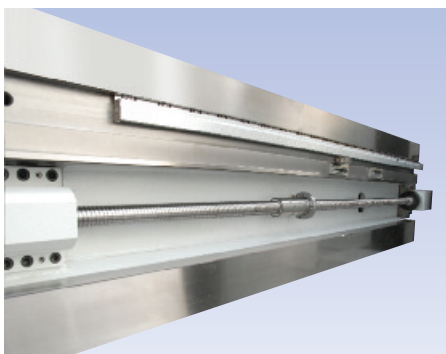

### ■ Guide Ways

The wide box type guide ways are induction-hardened and precision-ground. Mating surfaces of the sliding components are coated with fluoroelastic resin and are hand scraped for perfect fit. Fully automatic metered lubrication system provided.

### ■ Axis Drives

Each axis is driven by a high precision ballscrew and is powered by a high torque, maintenance free Fanuc digital AC servo motor. Ballscrews are supported on both ends by high precision bearings. The optional X axis linear scale feed back system combined with double anchor pretensioned design assures outstanding machining accuracy and repeatability. Rapid traverse rate of both X & Z axes is 7500mm/min (295 ipm).



### Table Torque & Power Diagram

#### VTB-100

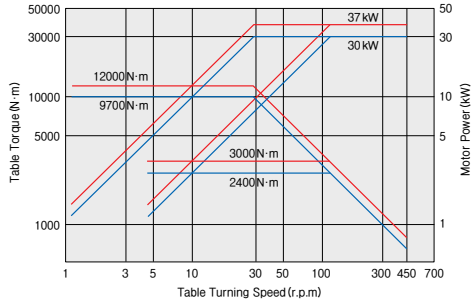

#### VTB-125 VTB-140

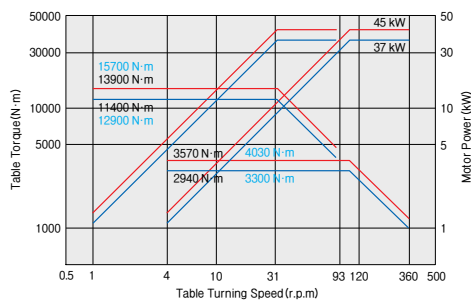

#### VTB-160

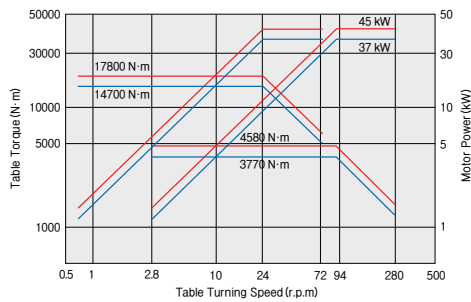

#### VTB-200E

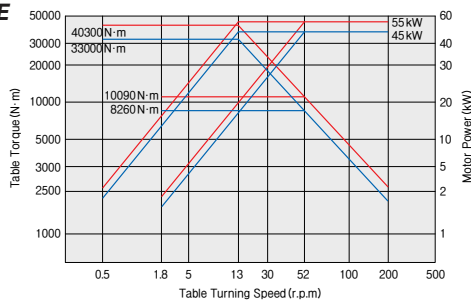

#### VTB-250E

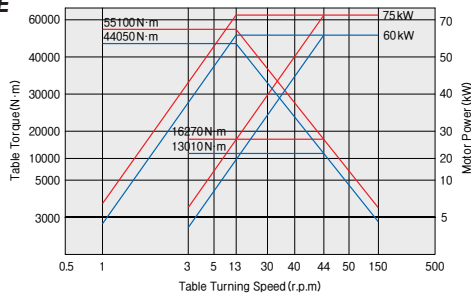

— 30min Operating Zone  
— Continues Operating Zone

### Ram Head Cutting Capability

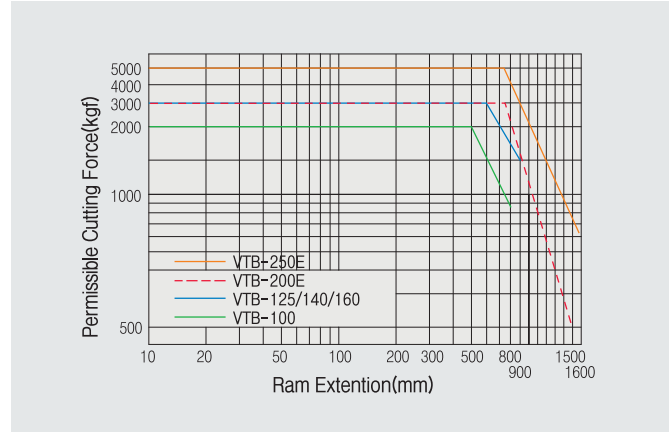

### Machining Range

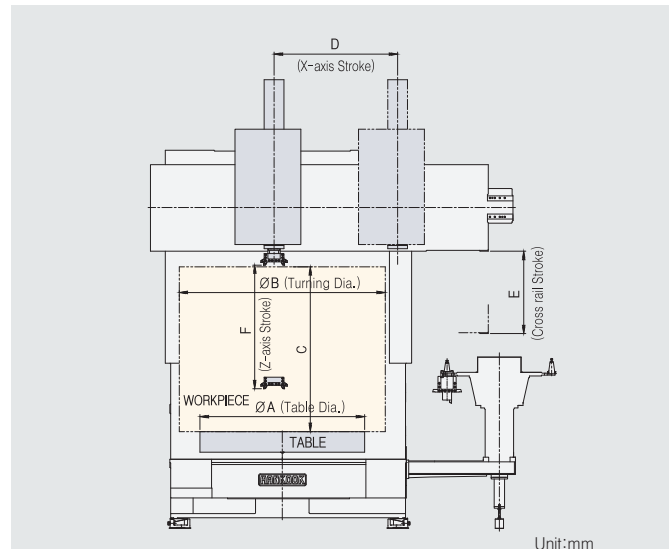

	VTB/VTC					
	100	125(E)	140(E)	160(E)	200E	250E
A	1000	1250	1400	1600	2000	2500
B	1250	1600	1600	2000	2500	3000
C	800 [750]	900 (1400)	[850 (1350)]		2000	2000
D	885	1060	1060	1260	1500	1700
E	—		(700)		1000	1000
F	800		900		1500	1600

※ [ ] : Hydraulic Chuck

#### Minimum Boring

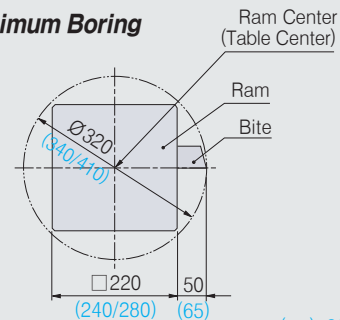

※ ( ) : 200E/250E

## Machine Specifications

Items	Unit	VTB/VTC								
		100T	100	125 125E	140 140E	160 160E	200E	250E		
Capacity	Max. turning diameter	mm (inch)	1250(49.2)		1600(63)		2000(78.7)	2500(98.4)	3000(118)	
	Max. turning height	mm (inch)	800(31.5)		900(35.4)		1400(55.1)	2000(78.7)	2000(78.7)	
	Max. torque	N·m (kg·m)	12000(1225)		13900(1420)	15700(1600)	17800(1820)	40300(4120)	55100(5620)	
	Max. cutting force	kgf (lbs)	2000(4410)		3000(6615)		3000(6615)	5000(11020)	5000(11020)	
	Max. workpiece weight	kg (lbs)	4000(8820)		8000(17640)		10000(22100)	12000(26000)	15000(33000)	
Table	Table diameter	mm (inch)	1000(39.4)		1250(49.2)	1400(55.1)	1600(63)	2000(79)	2500(98.4)	
	Table speed	rpm	1.1~450		0.9~360	0.8~320	0.7~280	1~200	1~150	
	Table speed range	step	Auto. 2-step							
C-axis (VTC)	Min. index angle	deg.	0.001°							
	Cutting feedrate	deg/min	0~900				0~720			
	Max. speed	rpm	3				2			
Ram Head	Tool size	mm (inch)	□ 32(□1 1/4)						□ 50(□2)	
	Spindle taper	-	ISO 7/24 No.50							
	Mill spindle speed	rpm	30~3000						15~1500	
	Max. mill spindle torque	N·m	-	186	235			280	280	
	Ram cross section	mm (inch)	220×220(8.66×8.66)					240×240(9.4×9.4)	280×280(11×11)	
Travel & Feedrate	X-axis travel(Saddle horizontal)	mm (inch)	885(35)		1060(42)		1260(50)	1500(59.1)	1700(67)	
	Z-axis travel(Ram Vertical)	mm (inch)	800(31.5)		900(35.4)		900(35.4)	1500(59.1)	1600(63)	
	Vertical travel of cross rail	mm (inch)	-		700(27.5)		1000(39.4)			
	X/Z-axis cutting feedrate	mm/min (ipm)	Max.3000(118)				Max.3000(118)			
	X/Z-axis rapid traverse	mm/min (ipm)	7500(295)				7500(295)			
	Cross rail rapid traverse	mm/min (ipm)	-		300(11.8)		300(11.8)			
ATC	Type of tool holder	-	MAS BT50							
	Tool magazine capacity	VTB	Turning 6-tool : VTB-100T, Turning 12-tool : VTB-100/125/140/160/200E/250E							
		VTC	16-tool (Turning 8, Milling 8) : VTC-100 24-tool (Turning 12, Milling 12) : VTC-125/140/160/200E/250E							
	Max. tool weight	kg (lbs)	70(154)				70(154)	90(198)		
Type of pull stud	-	P50T-I : VTB/DIN. 69872.50 .A : VTC								
Motor	Table motor	kW (Hp)	AC 30/37(40/50)		AC 37/45(50/60)		AC 45/55(60/73)	AC 60/75(80/100)		
	Mill spindle motor	(Cont./30min)	-	AC 11/15	AC 15/18.5(20/25)		AC 18.5/22(25/30)	AC 22/26(30/35)		
	C-axis motor	kW (Hp)	-	AC 4(5.3)	AC 7(9.3)		AC 9(12)	AC 9(12)		
	X/Z-axis servo motor	kW (Hp)	AC 4(5.3)		AC 7(9.3)		AC 7(9.3)	AC 9/4(2EA)		
Power Source	Input power supply	-	AC 200/220V ±10%, 50/60Hz ±1%							
	Power capacity	kVA	85		110		130	230		
Machine Size	Floor space	-	Refer to page 14							
	Weight	kg (lbs)	18000 (39700)	18500 (40800)	19000/25800 (41900/56900)	24300/26100 (53600/57500)	28800/30900 (63500/68200)	61700 (136000)	78000 (172000)	
CNC Controller		-	FANUC 0i series							

## Standard Accessories

- CNC controller, FANUC 0i series
- Table and servo drives and motors
- 4-jaw independent chuck
- Automatic tool changer system
- Lubrication oil cooler
- C-axis scale (Only for VTC)
- Hydraulic power unit
- Automatic lubrication system for guides
- Coolant system and Washer coolant
- Through tool coolant
- Through spindle coolant (Only for VTC)
- Splash guard and safety guard rail
- X-axis slideway protect steel cover
- Work light
- Patrol lamp (Red, Yellow, Green)
- NC power off
- Chip pan
- Levelling blocks
- Foundation bolts and nuts
- Tool box with maintenance tools
- Square tool holder (0161)
- Boring tool holder (5143)

## Optional Accessories

- APC type (2-pallet, 3-station)
- Hyd. 3-jaw & manual 4-jaw combination chuck (Ø1000, 1250, 1400, 1600, 2000mm)
- Chip conveyor & bucket
- Scale feedback (X/Z-Axis)
- Tool setter
- Work probe
- High pressure coolant system
- Air-conditioner for electrical cabinet
- High cooler for operation panel
- Transformer
- A.V.R
- Tool holders
- Couvic coupling type tool holder clamp device



## ■ CNC System Specifications (FANUC 0i series)

### Standard Function

Controlled Axis	
Controlled axes	3 axes(X, Z, C)
Simultaneously controlled axes	3 axes
Increment system	0.001mm(0.0001")
HRV3 control	
Flexible feed gear	Optional DMR
Interlock	All/each axis, each direction, block start, cutting block start
Machine lock	All/each axis
Emergency stop	
Over travel	
Stored stroke check 1	
Mirror image	All/each axis
Follow-up	
Servo off/mechanical handle	
Chamfering on/off	
Inch / Metric conversion	
MANUAL GUIDE i	
Play back	
Embedded ethernet	

Operation	
Automatic operation	
MDI operation	
DNC operation with memory card	CF Card
Program number search	
Sequence number search	
Wrong operation prevention	
Buffer register	
Dry run	
Single block	
Manual continuous feed(jog)	
Manual reference position return	
Reference position setting without DOG	
Incremental feed	x1, x10, x100
Program restart	
Manual handle feed 1-unit	1-unit
Handle interruption	

Accuracy Compensation Function	
Backlash compensation	
Backlash compensation for each rapid traverse and cutting feed	
Stored pitch error compensation	



Interpolation Functions	
Nano interpolation	
Positioning	G00
Exact stop mode	G61
Tapping mode	G63
Cutting mode	G64
Exact stop	G09
Linear interpolation	
Circular interpolation	
Dwell	
Thread cutting, synchronous cutting	
Multi threading	
Continuous threading	
Skip	G31
Torque limit skip	
Reference position return	G28
Reference position return check	G27
2nd reference position return	G30

Feed Functions	
Rapid traverse rate	MAX 999.999 m/min(1um)
Rapid traverse override	F0, 50, 100%(1step)
Feed per minute	G98 mm/min
Feed per revolution	G99 mm/rev
Tangential speed constant control	
Cutting feedrate clamp	
Automatic acceleration/deceleration	Rapid traverse: linear Cutting feed: exponential, linear
Rapid traverse bell-shaped acceleration/deceleration	
Feedrate override	0-200%
Jog override	0-200%
Override cancel	
Manual per revolution feed	
Linear acc/dec after cutting feed interpolation	

Program Input	
Tape code	EIA / ISO
Label skip	
Control in/out	
Optional block skip	1
Max. programmable dimension	±9 digit
Program file name	32 characters
Sequence number	N8 digit
Absolute/incremental programming	Combined use in the same block

Decimal point programming/pocket calculator type	
decimal point programming	
Input unit 10 time multiply	
Diameter/radius programming	
Plane selection	G17, G18, G19
Automatic coordinate system setting	
Manual absolute on and off	
G code system	A
Programmable data input	G10
Programmable parameter input	
Sub program call	10 folds nested
Canned cycle	
Circular interpolation by R programming	R, I, J, K 12digit
Coordinate system shift	
Direct input of coordinate system shift	
Chamfering/corner R	

Tool Function/Tool Compensation	
Tool function	
Tool offset pairs	128-pairs
Tool offset	
Tool offset value counter input	
Direct input of tool offset value measure	
Tool geometry/wear Compensation	

Auxiliary/Spindle Functions	
Auxiliary function	M8 digit
Auxiliary function lock	
High-speed M/S/T/B interface	
Spindle speed function	S5 digit, binary output
Rigid tap	

Editing Operation	
Part program storage size	2Mbyte
Number of registerable programs	Max.1000EA
Part program editing	
Program protect	
Extended Part program editing	
Memory card program edit & operation	
Background editing	

Setting and Display	
MDI/display unit	15" color LCD 10.4" color LCD/MDI full key (for VTB/VTC-100)
Status display	
Lock function	
Current position display	
Program comment display	31 characters
Parameter setting and display	
Alarm display	
Alarm history display	
Operation history display	
Actual cutting feedrate display	
Servo setting screen	
Servo waveform display	
Maintenance information screen	
Multi-language display	
Data protection key	4 type
Self-diagnosis function	
Run hour and parts count display	

Data input/output	
RS-232C interface	
External data input	
External key input	
External workpiece number search	9999
Memory card input/output	
USB memory input/output	
Screen hard copy	
Automatic data backup	

### Optional Function

Optional Functions	
Stored stroke check 2, 3	
DNC operation	
Retraction for Rigid tapping	
High speed program check	
Single direction positioning	G60
Helical interpolation	Circular interpolation plus max. 2 axes linear interpolation
Variable lead thread cutting	
Polygon turning	
3rd / 4th reference point return	
Programmable mirror image	
Spindle orientation	1 spindle
Tool offset pairs	64/99/200/400 pairs
Tool pair for tool management function	64/240/1000 tools
Part program storage size	1/2/4/8 Mbyte
Remote diagnostic	
Reader / punch interface	Ch.2



## ■ Accessories

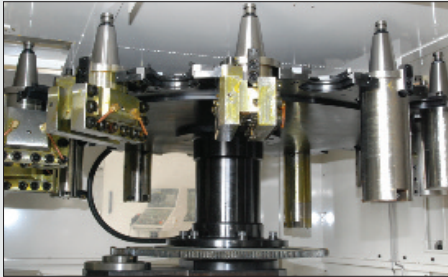

Automatic Tool Changer

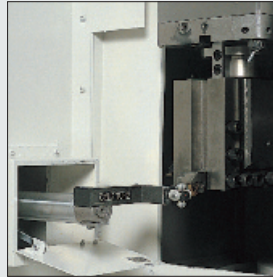

Tool Setter

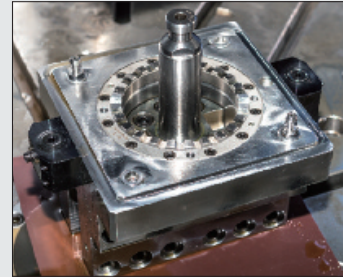

Couvic Coupling type Tool Holder



Work Probe

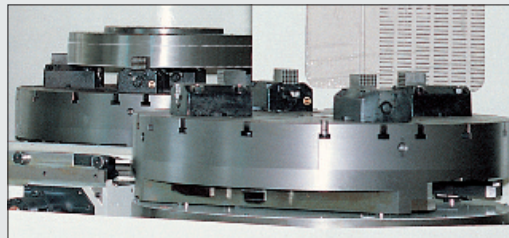

Automatic Pallet Changer(2 pallets)



Hydraulic Chuck

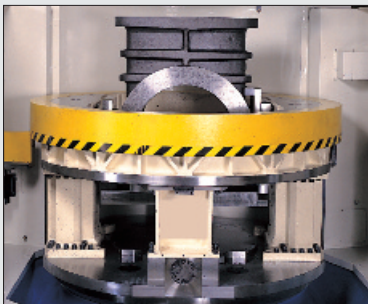

Automatic Index Chuck  
(for machining large valve)



Automatic Index Chuck  
(for machining small valve)

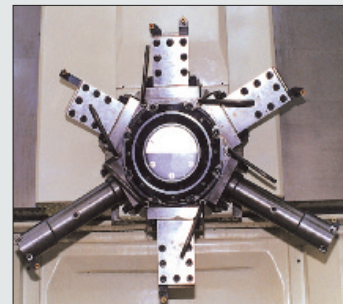

Electrical V-6 Turret(VTB-100T only)

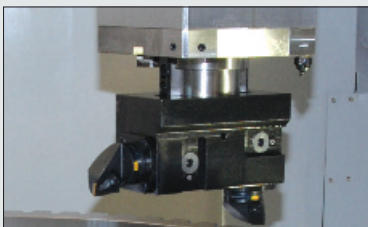

Capto Tool Holder (C6/C8)



Grinding Attachment



C-axis Brake



Turning Tool Holders (Option)

VTB-100/125/140/160/200E

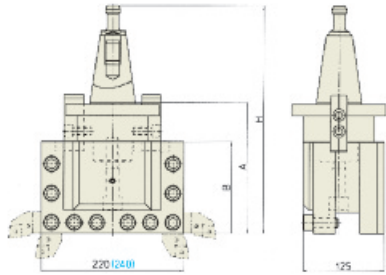

● Square tool holder

( ) : 200E

Model	A	B	H	Tool Size
TA12E41000-0060 (TE20B41000-0060)	160	100	306.8	□32(□11/4)
TA12C41000-0061 (TE20A41000-0061)	200	140	346.8	□32(□11/4)
TA12C41000-0062 (TE20A41000-0062)	250	190	396.8	□32(□11/4)

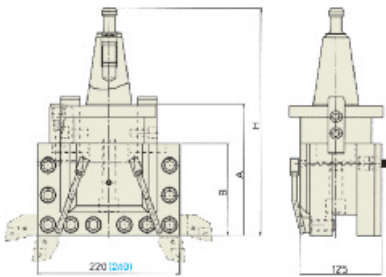

● Square tool holder (Through tool coolant)

( ) : 200E

Model	A	B	H	Tool Size
TA12F41000-0160 (TE20A41000-0160)	160	100	306.8	□32(□11/4)
TA12D41000-0161 (TE20A41000-0161)	200	140	346.8	□32(□11/4)
TA12D41000-0162 (TE20A41000-0162)	250	190	396.8	□32(□11/4)

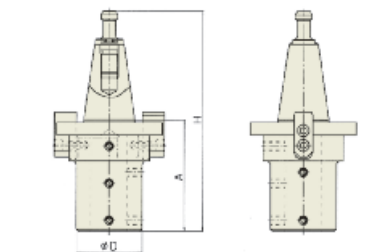

● Side lock holder

Model	A	H	D	Tool Size
TA12B41000-5350	110	256.8	φ 55	φ 25 (φ 1)
TA12B41000-5360	110	256.8	φ 62	φ 32 (φ 1 1/4)
TA12B41000-5370	160	306.8	φ 70	φ 40 (φ 1 1/2)
TA12B41000-5380	160	306.8	φ 90	φ 50 (φ 2)

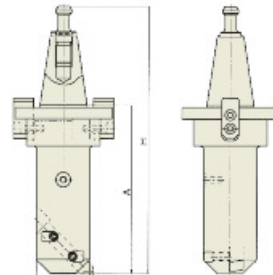

● Boring tool holder (BA type)

Model	A	H	D	Tool Size
TA12B41000-5040	200	346.8	φ 80	□20(□3/4)
TA12B41000-5041	250	396.8	φ 80	□20(□3/4)
TA12B41000-5042	300	446.8	φ 80	□20(□3/4)
TA12B41000-5043	350	496.8	φ 80	□20(□3/4)
TA12B41000-5050	200	346.8	φ 110	□25(□1)
TA12B41000-5051	250	396.8	φ 110	□25(□1)
TA12B41000-5052	300	446.8	φ 110	□25(□1)
TA12B41000-5053	350	496.8	φ 110	□25(□1)

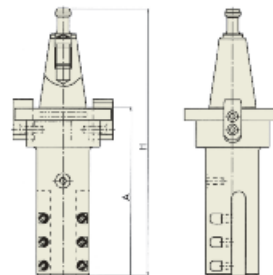

● Boring tool holder (BP type)

Model	A	H	D	Tool Size
TA12B41000-5140	200	346.8	φ 80	□20(□3/4)
TA12B41000-5141	250	396.8	φ 80	□20(□3/4)
TA12B41000-5142	300	446.8	φ 80	□20(□3/4)
TA12B41000-5143	350	496.8	φ 80	□20(□3/4)
TA12B41000-5150	200	346.8	φ 110	□25(□1)
TA12B41000-5151	250	396.8	φ 110	□25(□1)
TA12B41000-5152	300	446.8	φ 110	□25(□1)
TA12B41000-5153	350	496.8	φ 110	□25(□1)

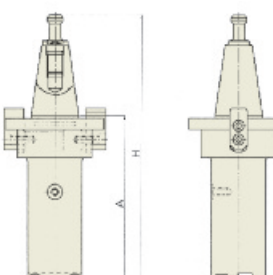

● Boring tool holder (BF type)

Model	A	H	D	Tool Size
TA12B41000-5240	200	346.8	φ 80	□20(□3/4)
TA12B41000-5241	250	396.8	φ 80	□20(□3/4)
TA12B41000-5242	300	446.8	φ 80	□20(□3/4)
TA12B41000-5243	350	496.8	φ 80	□20(□3/4)
TA12B41000-5250	200	346.8	φ 110	□25(□1)
TA12B41000-5251	250	396.8	φ 110	□25(□1)
TA12B41000-5252	300	446.8	φ 110	□25(□1)
TA12B41000-5253	350	496.8	φ 110	□25(□1)

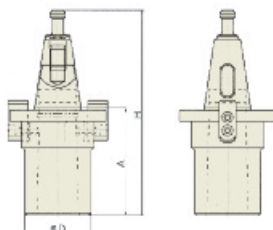

● Morse taper holder (MS type)

Model	A	H	D	Tool Size
TA12B41000-5450	110	256.8	φ 85	MT No.5
TA12B41000-5460	160	306.8	φ 100	MT No.6

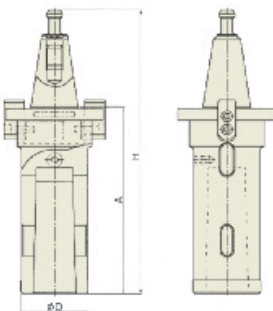

● Morse taper holder (ML type)

Model	A	H	D	Tool Size
TA12B41000-5550	240	386.8	φ 85	MT No.5
TA12B41000-5560	290	436.8	φ 100	MT No.6

Unit : mm (inch)

## VTB-250E

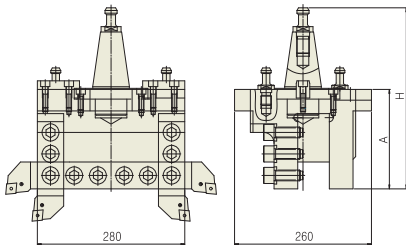

### ● Square tool holder (Standard type)

Model No.	A	H	Tool Size
TL25A41000-0060	185	336.8	□ 50
TL25A41000-0061	235	386.8	□ 50
TL25A41000-0062	285	436.8	□ 50

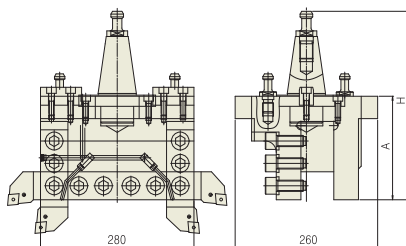

### ● Square tool holder (Through tool coolant)

Model No.	A	H	Tool Size
TL25A41000-0160	185	336.8	□ 50
TL25A41000-0161	235	386.8	□ 50
TL25A41000-0162	285	436.8	□ 50

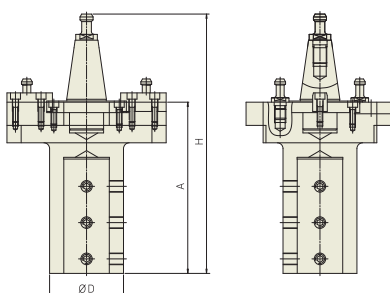

### ● Side lock holder

Model No.	A	D	H	Tool Size
TL25A41000-5350	220	∅ 80	371.8	∅ 40
TL25A41000-5360	220	∅ 100	371.8	∅ 50
TL25A41000-5370	245	∅ 100	396.8	∅ 60
TL25A41000-5380	295	∅ 130	446.8	∅ 80

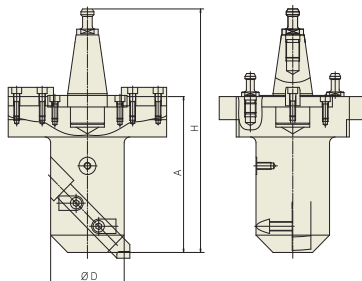

### ● Boring tool holder (BA type)

Model No.	A	D	H	Tool Size
TL25A41000-5040	270	∅ 130	421.8	□ 32
TL25A41000-5041	320	∅ 130	471.8	□ 32
TL25A41000-5042	370	∅ 130	521.8	□ 32
TL25A41000-5043	420	∅ 130	571.8	□ 32

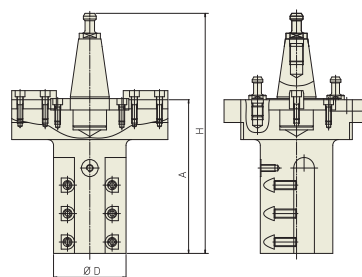

### ● Boring tool holder (BP type)

Model No.	A	D	H	Tool Size
TL25A41000-5140	270	∅ 130	421.8	□ 32
TL25A41000-5141	320	∅ 130	471.8	□ 32
TL25A41000-5142	370	∅ 130	521.8	□ 32
TL25A41000-5143	420	∅ 130	571.8	□ 32

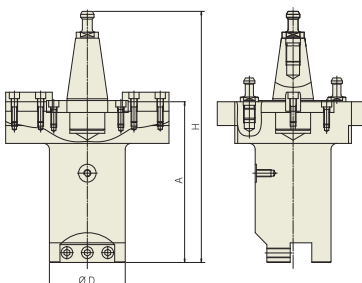

### ● Boring tool holder (BF type)

Model No.	A	D	H	Tool Size
TL25-41000-5240	270	∅ 130	421.8	□ 32
TL25-41000-5241	320	∅ 130	471.8	□ 32
TL25-41000-5242	370	∅ 130	521.8	□ 32
TL25-41000-5243	420	∅ 130	571.8	□ 32

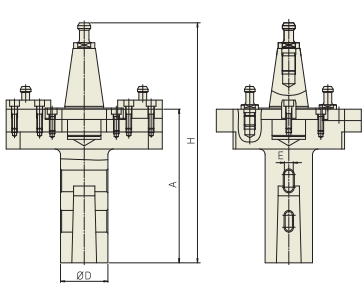

### ● Morse taper holder

Model No.	A	D	H	Tool Size
TL25A41000-5450	270	∅ 85	421.8	MT # 5
TL25A41000-5460	345	∅ 110	496.8	MT # 6
TL25A41000-5470	420	∅ 130	571.8	MT # 7



## CNC Vertical Boring & Turning Mills **VTB/VTC** Series Line-up



VTB-100T



VTB(C)-100



VTB(C)-F series



VTB(C)-E series

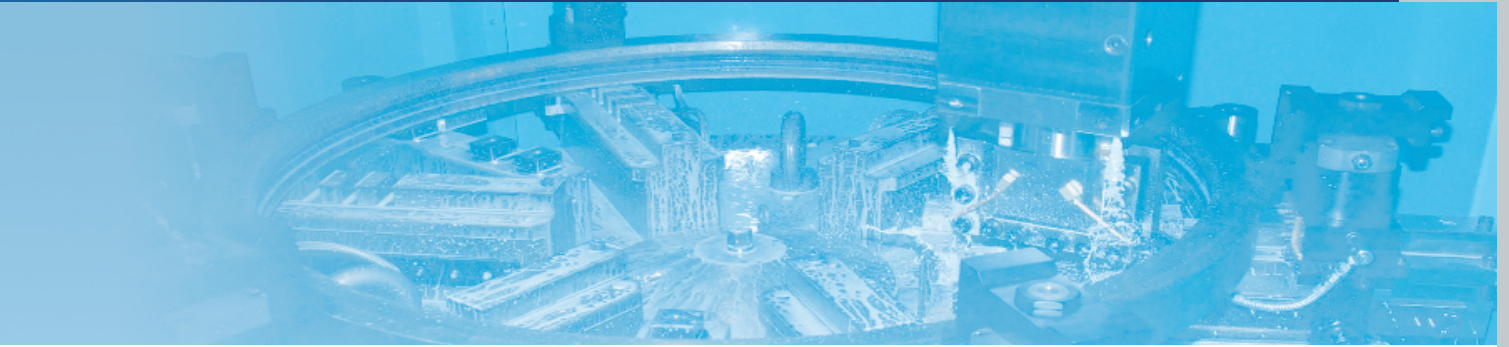

VTB-V series



VTB(C)-APC



VTC-200E

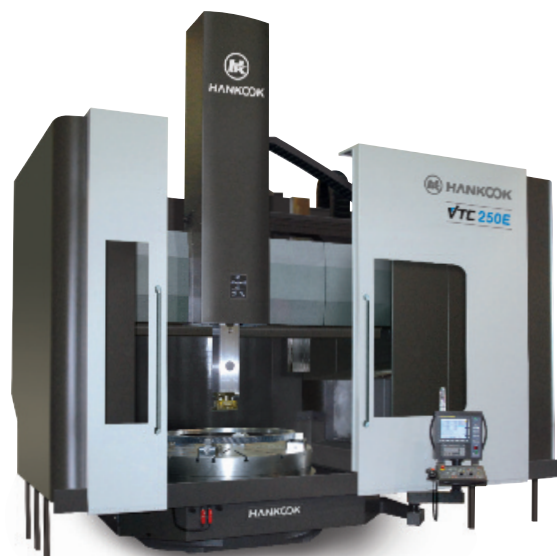

VTC-250E



**External Dimensions**

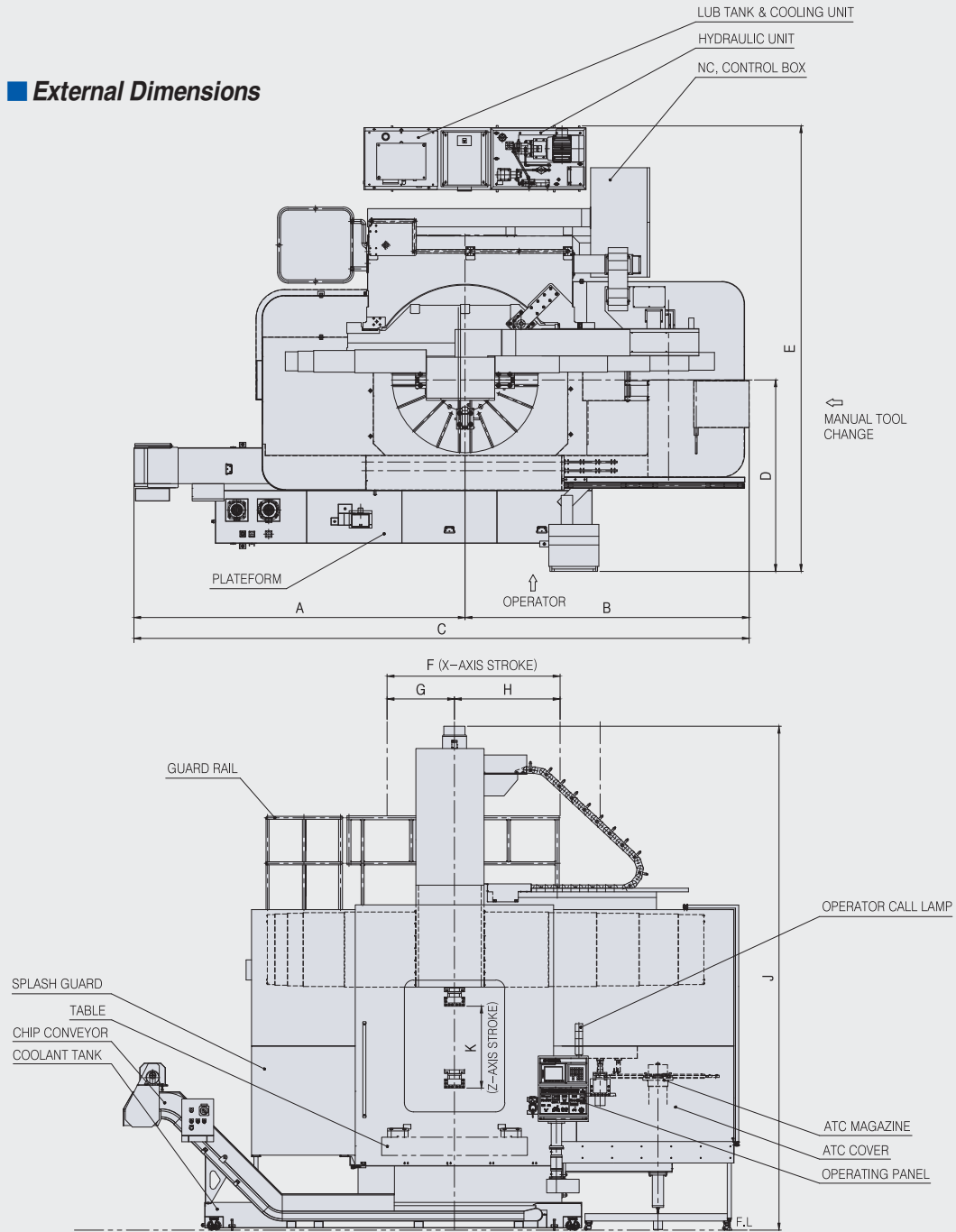

Unit:mm

MODEL	A	B	C	D	E	F	G	H	J (VTB/VTC)	K
VTB/VTC 100	3080	2735	5815	1530	4565	885	100	785	4530/4790	800
125/140(E)	3600	3050	6650	1700	4335	1060	100	960	4790(5290)/5035(5535)	900
160(E)	3850	3240	7090	1855	4625	1260	100	1160	4790(5290)/5035(5535)	900
200E	4245	3630	7875	2450	6325	1500	100	1400	7260	1500
250E	4620	4540	9160	2650	6080	1700	100	1600	7710	1600



**Applications**

**Wind Power Components**



Gear Rim



Rotor Break Disk



Yaw Ring

**Valve & Pump Components**



Valves



Valves

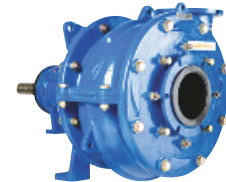

Pumps

**Industrial Components**

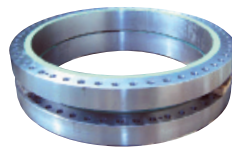

Flange



Tube sheet



Self reinforced nozzle

**Vehicle Components**



Aircraft engine impeller



Rail wheel



Ring gear

**Ship Components**



Gear wheel supply unit



Intermediate wheel supply unit



Intermediate wheel



#### HEAD OFFICE & PLANT

**Hankook Machine Tools Co. LTD.**  
80-1, Jangbang-ro, hallim-myeon, Gimhae-si,  
Gyeongsangnam-do, 50849 Korea  
Tel:+82-55-282-7781 Fax:+82-55-342-9771  
eMail: [hansale@hanmachine.com](mailto:hansale@hanmachine.com)  
Internet: [www.hanmachine.com](http://www.hanmachine.com)

#### GENERALIMPORTEUR, VERTRI EB & SERVICE

**JS Werkzeugmaschinen GmbH**  
Wesserstraße 228, 32547 Bad Oeynhausen / Germany  
Tel: +49 5731 - 15 64 364  
eMail: [info@js-wzm.de](mailto:info@js-wzm.de)  
Internet: [www.js-wzm.de](http://www.js-wzm.de) | [www.hankookeurope.eu](http://www.hankookeurope.eu)

#### VERTRIEB & SERVICE

**Stiens Werkzeugmaschinen Handelsgesellschaft mbH**  
Mittelweg 92 - 94, 59302 Oelde / Germany  
Tel: +49 25 22 - 83 49 112  
eMail: [info@stiens.de](mailto:info@stiens.de)  
Internet: [www.stiens.de](http://www.stiens.de) | [www.hankookeurope.eu](http://www.hankookeurope.eu)